

SPECIFICATIONS

Power	7.5kW / 10HP
Frequency	50Hz
Discharge Elbow Outlet	DIN PN16 150mm / 6 inch
Weight (Excl cable)	221Kg
Solid Passage	70 mm
Phase	3ø
Voltage	415
Full Load Ampere	15.2
Maximum Liquid Temperature	0-40° C
Maximum Submersion Depth	30m (100 feet)
Motor type	Dry motor
Motor Speed	4 Pole (1440 rpm)
Motor Insulation	Class F
Motor Protection	IP68
Protector	Auto cut
Motor Bearings	Ball Type
Seal Method	Dual Mechanical seal Upper: Carbon/Ceramic Lower: Silicon/Silicon
Impeller Type	Enclosed Channel
Motor Cover Construction	FC-200 Cast Iron
Motor Casing Construction	FC-200 Cast Iron
Motor Shaft Construction	420J2 Stainless Steel
Pump Casing Construction	FC-200 Cast Iron
Impeller Construction	FC-200 Cast Iron
Strainer Construction	FC-200 Cast Iron
Cable Material	H07RN-F



UMDN7500/150/3

MODEL NUMBER STRUCTURE

UMDN7500/150/3

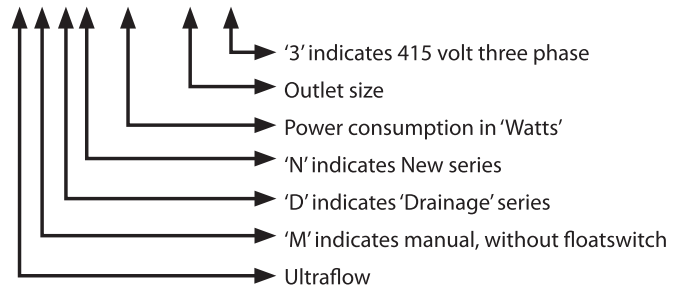

PERFORMANCE CURVES

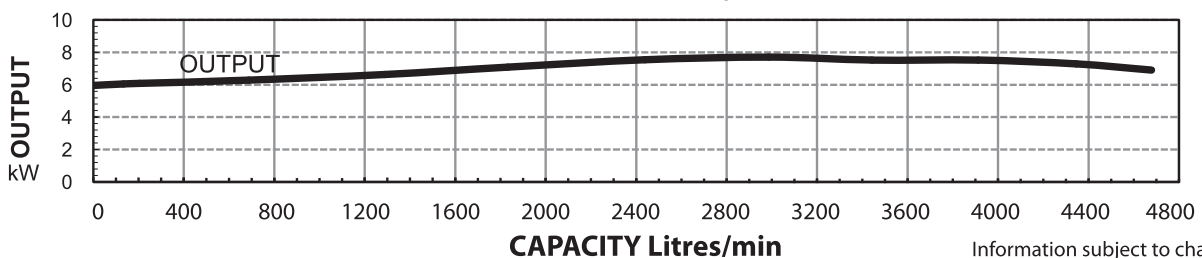
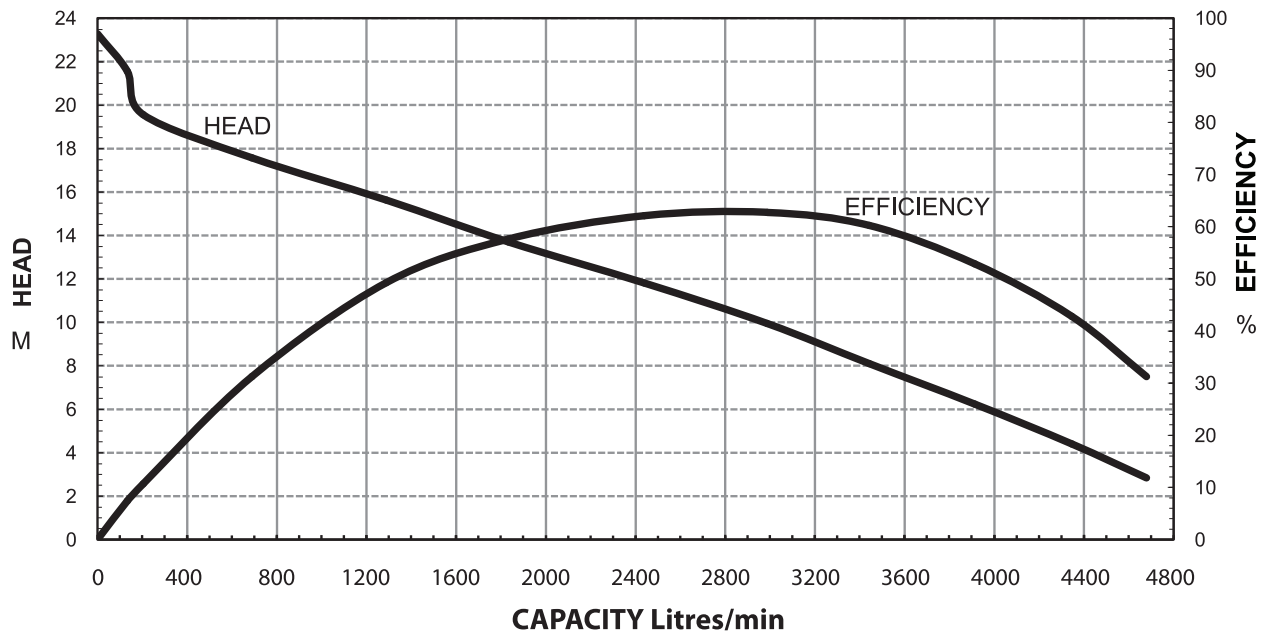

Information subject to change without notice.

SECTIONAL DRAWING & MATERIALS LIST

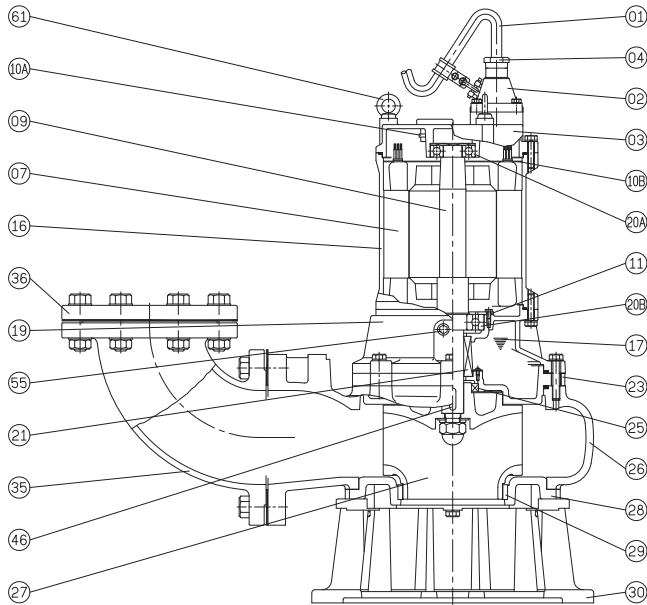

Part Number	Description	Material
01	Cable	HO7RN-F
02	Cable Gland Base	
03	Upper Bearing Housing /Motor Cap	Cast Iron FC-200
04	Cable Gland Base Cover	
07	Motor Stator	
09	Shaft With (With Rotor)	420J2 Stainless Steel
10A	Auto Cut Out Overload	
10B	Auto Cut Out Plate	
11	Bearing fixer	
16	Motor Casing	Cast Iron FC-200
17	Lubricant	Turbine Oil
19	Lower Bearing Housing	Cast Iron FC-200
20A	Upper Bearing	
20B	Lower Bearing	
21	Mechanical Seal	Upper: Carbon/Ceramic Lower: Silicon/Silicon
23	Mechanical Seal Housing	Cast Iron FC-200
25	Oil Seal	Nitrile
26	Pump Casing	Cast Iron FC-200
27	Impeller	Cast Iron FC-200
28	Casing Cover	Cast Iron FC-200
29	Impeller Bush	403 Stainless Steel
30	Pump Base Footing	Cast Iron FCD-450
35	Outlet Elbow	Cast Iron FC-200
36	Outlet Flange	Cast Iron FC-200
46	Impeller Key	304 Stainless Steel
47	O'rings	
55	Oil Plug	304 Stainless Steel
61	Eye Bolt	304 Stainless Steel

To order spare parts as above, it will be necessary to add the model number of the pump after the code listed above. For example, a power lead for a UMDN7500/150/3 would be written as '01-UMDN7500/150/3'.

DIMENSIONAL DRAWING

ELBOW (FLANGE) SET EB6-240

GUIDE RAIL SYSTEM DIMENSIONS USING GR150 GUIDE RAIL KIT

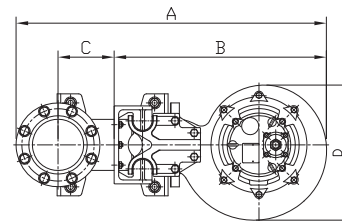
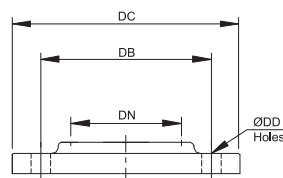
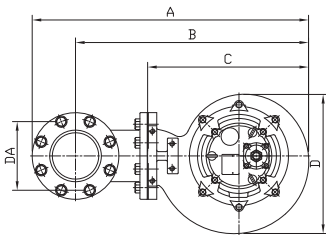

DIMENSIONS - mm				
DN	DB	DC	DD	Holes
150	240	280	19	8

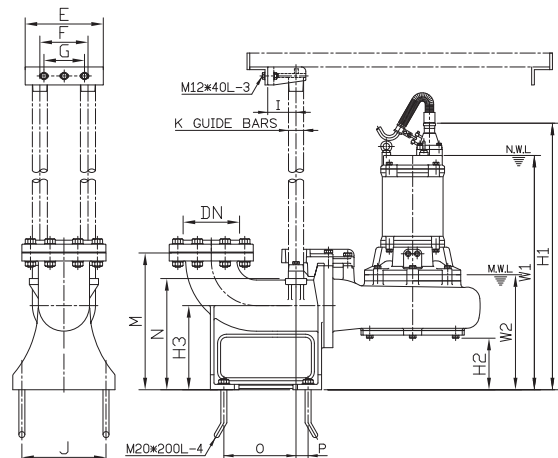
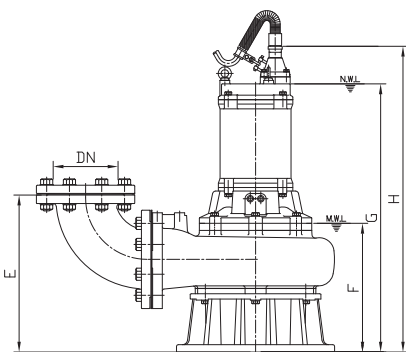

DIMENSIONS - mm									
UMDN7500/150/3									
DN	DA	A	B	C	D	E	F	G	H
150	240	888	748	559	449	493	365	762	870

DIMENSIONS - mm																			
UMDN7500/150/3																			
DN	A	B	C	D	E	F	G	I	J	K	M	N	O	P	W1	W2	H1	H2	H3
150	1035	708	187	449	260	160	135	95	280	50	455	370	240	40	779	382	887	182	280

Information subject to change without notice.

PUMP BASE FOOTING TO BE UNBOLTED FOR GUIDE RAIL APPLICATIONS